

FCI CONFIDENTIAL

PRODUCT NUMBER
53425-000
53425-000LF

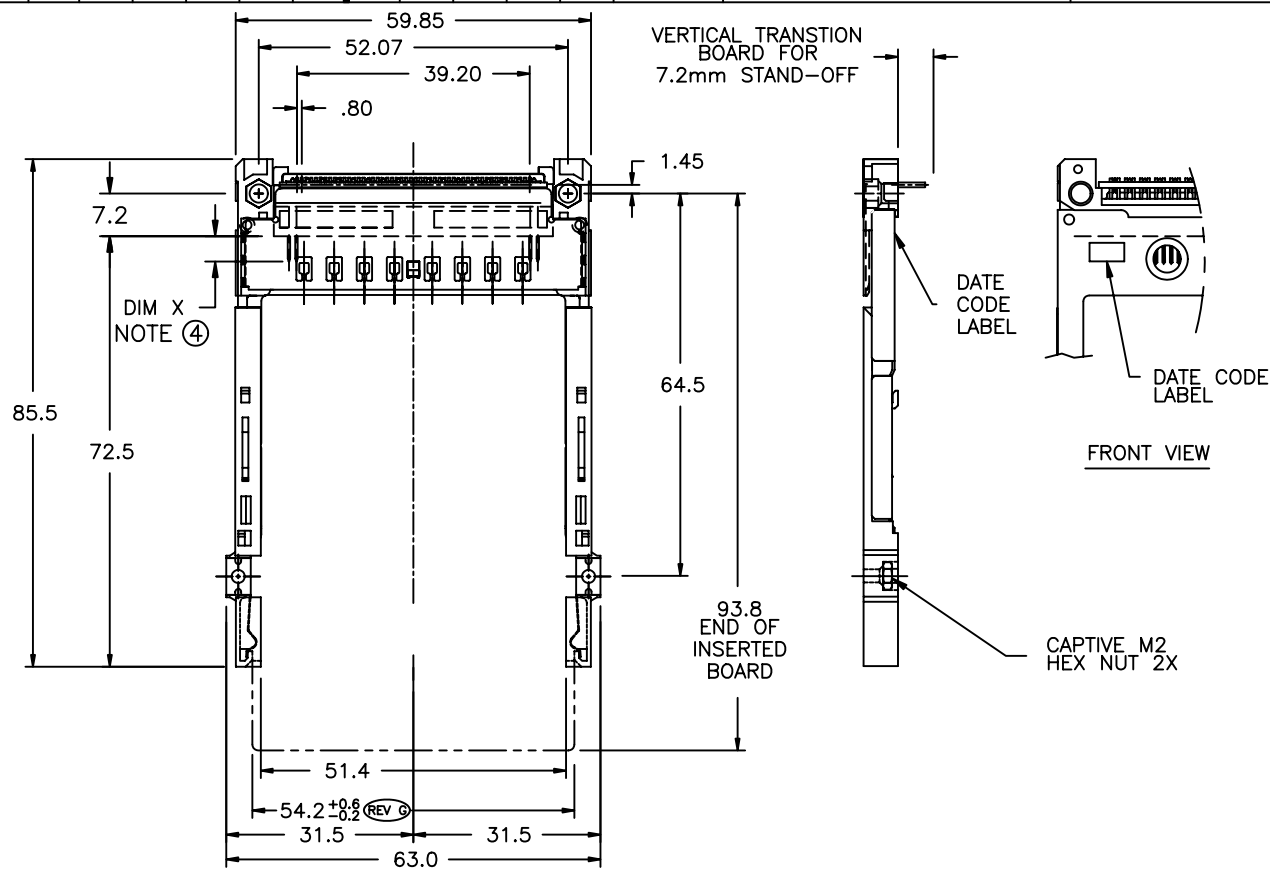

MATING RECEPTACLE SHOWN FOR APPLICATION CLARITY ONLY. MUST BE ORDERED SEPARATELY

DESCRIPTION

3.3 V SINGLE DECK ASSEMBLY WITH NON-EJECT MECHANISM

- HEADER HAS VERTICAL TRANSITION BOARD FOR 7.2mm STAND-OFF.
- STAND-OFF PROVIDED BY CUSTOMER

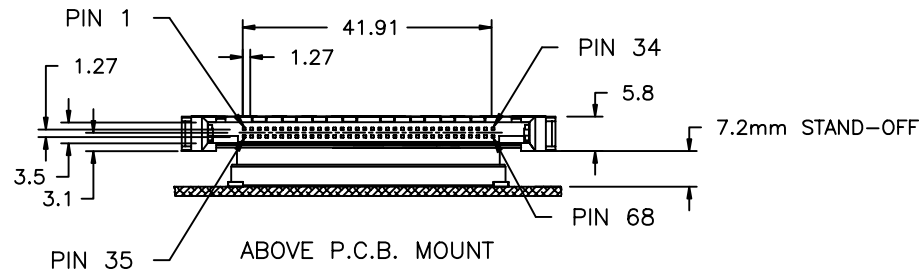

DATE CODE = ABBC

DAY OF WEEK  
WEEK  
YEAR

EXAMPLE: 1043=3rd DAY OF 4th WEEK OF 2001

mat'l. code		surface		tolerance		projection		product family	
		ISO 1302		ISO 406 ISO 1101		MM		CARDBUS	
ltr	ecn no	dr	date	tolerances unless otherwise specified		title		3.3 V CARDBUS ASSEMBLY	
C	V02254	RGD	10/31/00	angles	.X±.3				
D	V10949	TFG	3/1/01	linear	.XX±.13				
E	V11512	TFG	4/27/01	±2'	.XXX±.051	scale 1:1			
F	N05-0073	WB	03/14/05	dr	R.G. Draggoo	5/15/00		dwg no	
G	N07-0009	MZ	01/10/07	enr	D.BRANN	5/15/00		sheet 1 of 5 size	
				chr	D.BRANN	5/15/00		53425 A4	
				appd	D.BRANN	5/15/00		type CUSTOMER Drawing	
sheet	revision	G	G	G	G				
index	sheet	1	2	3	4				

This document is the property of and embodies CONFIDENTIAL and PROPRIETARY information of FCI. No part of the information shown on this document may be used in any way or disclosed to others without the written consent of FCI. Copyright FCI.

FCIconnect.com

FCI CONFIDENTIAL



FCIconnect.com

This document is the property of and embodies CONFIDENTIAL and PROPRIETARY information of FCI. No part of the information shown on this document may be used in any way or disclosed to others without the written consent of FCI. Copyright FCI.

PRODUCT NUMBER
53425-500
53425-500LF

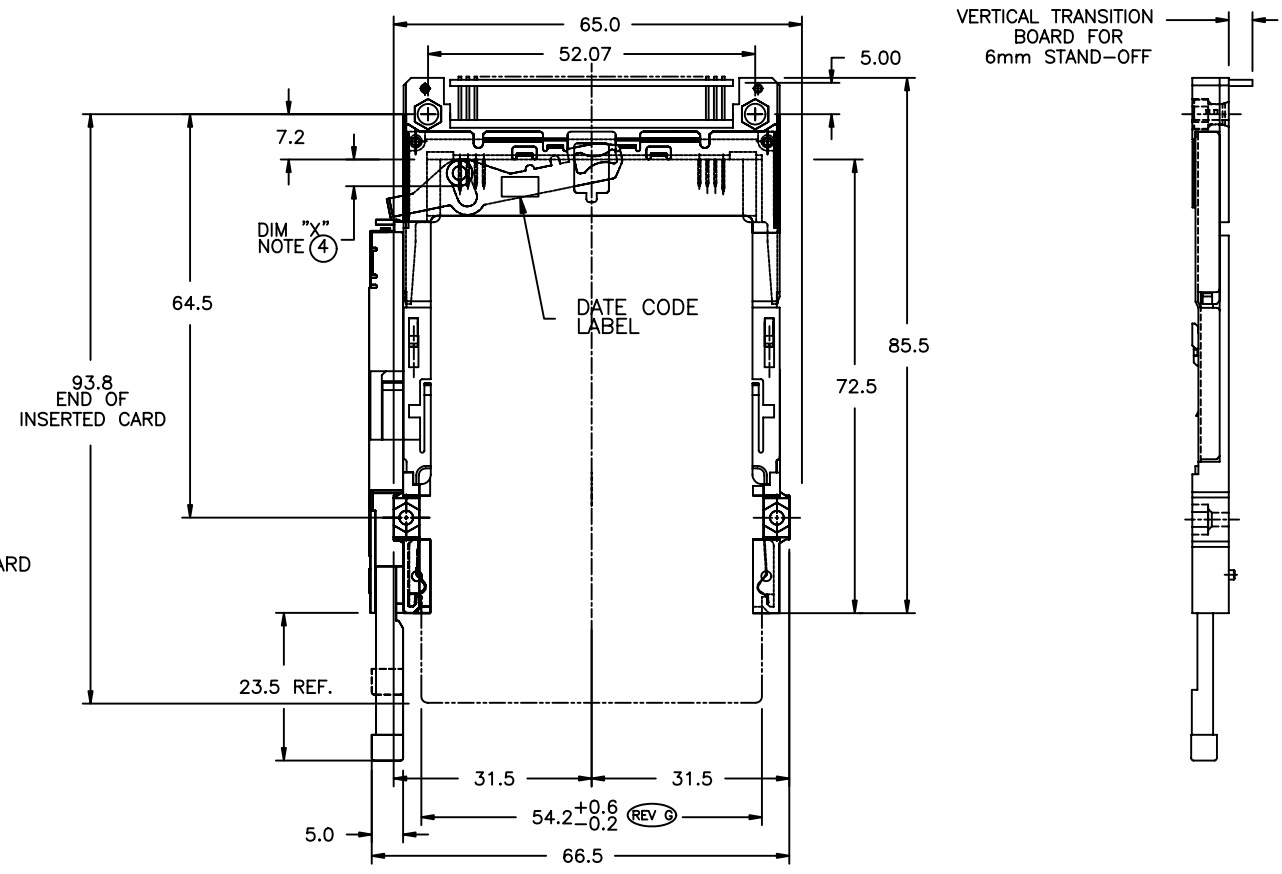

MATING RECEPTACLE SHOWN FOR APPLICATION CLARITY ONLY. MUST BE ORDERED SEPARATELY

DESCRIPTION  
 3.3 V SINGLE DECK ASSEMBLY WITH EJECT MECHANISM  
 - HEADER HAS VERTICAL TRANSITION BOARD FOR 6mm STAND-OFF.  
 - STAND-OFF PROVIDED BY CUSTOMER

DATE CODE = ABBC  
 DAY OF WEEK  
 WEEK  
 YEAR

EXAMPLE: 1043=3rd DAY OF 4th WEEK OF 2001

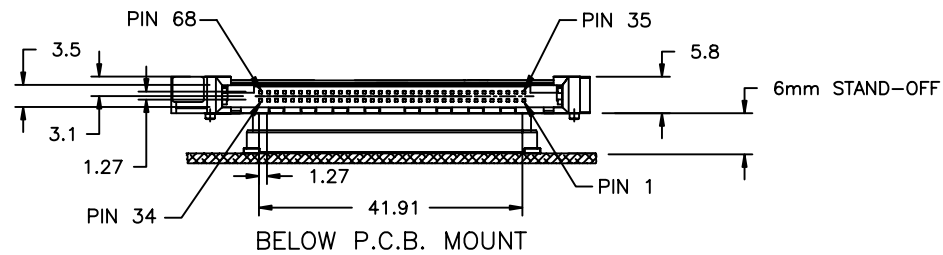

mat'l. code		surface	tolerance	projection	product family
ISO 1302		ISO 406	ISO 1101		CARDBUS
ltr		ecn no	dr	date	tolerances unless otherwise specified
G					angles
					linear
					±2'
					dr R.G. Draggoo 5/15/00
					enr D.BRANN 5/15/00
					chr D.BRANN 5/15/00
					appd D.BRANN 5/15/00
sheet	revision				
index	sheet				

title		product family	
3.3 V CARDBUS ASSEMBLY		CARDBUS	
dwg no		sheet 2 of 5 size	
53425		A4	
type		CUSTOMER Drawing	

FCI CONFIDENTIAL

PRODUCT NUMBER
53425-067
53425-067LF

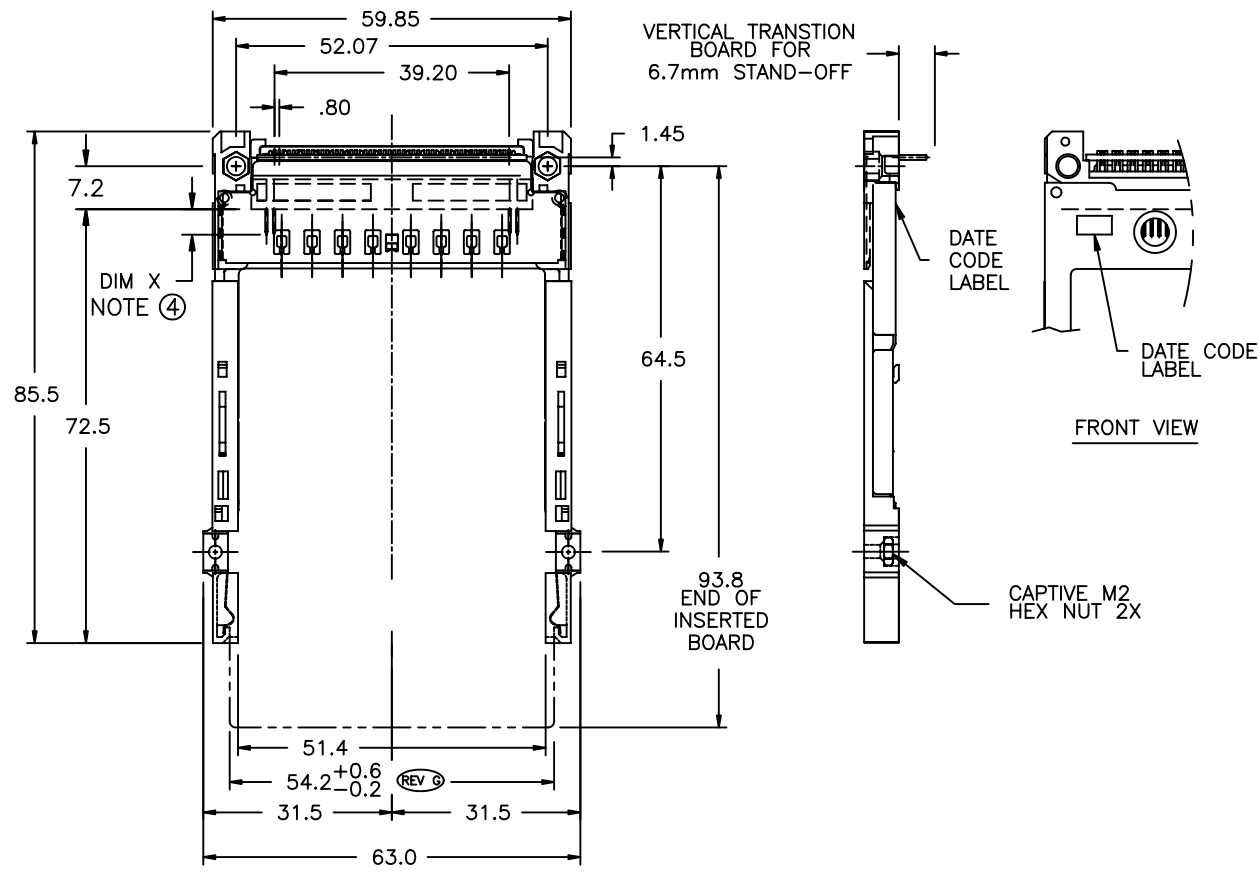

MATING RECEPTACLE SHOWN FOR APPLICATION CLARITY ONLY. MUST BE ORDERED SEPARATELY

DESCRIPTION  
 3.3 V SINGLE DECK ASSEMBLY WITH NON-EJECT MECHANISM

- HEADER HAS VERTICAL TRANSITION BOARD FOR 6.7mm STAND-OFF.
- STAND-OFF PROVIDED BY CUSTOMER

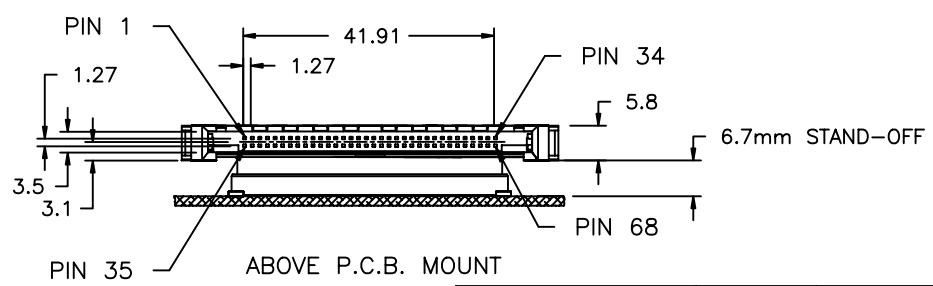

DATE CODE = ABBC

DAY OF WEEK  
 WEEK  
 YEAR

EXAMPLE: 1043=3rd DAY OF 4th WEEK OF 2001

mat'l. code		surface	tolerance	projection	product family
ISO 1302		ISO 406	ISO 1101	ISO 1101	CARDBUS
ltr	ecn no	dr	date	tolerances unless otherwise specified	title
G					3.3 V CARDBUS ASSEMBLY
angles		linear		MM	
.X±.3		.XX±.13		scale 1:1	
±2'		.XXX±.051			
dr		R.G. Draggoo		5/15/00	dwg no
enr		D.BRANN		5/15/00	sheet 3of 5 size
chr		D.BRANN		5/15/00	53425 A4
appd		D.BRANN		5/15/00	type CUSTOMER Drawing
sheet index	revision sheet				

This document is the property of and embodies CONFIDENTIAL and PROPRIETARY information of FCI. No part of the information shown on this document may be used in any way or disclosed to others without the written consent of FCI. Copyright FCI

FCI  
 FCIconnect.com

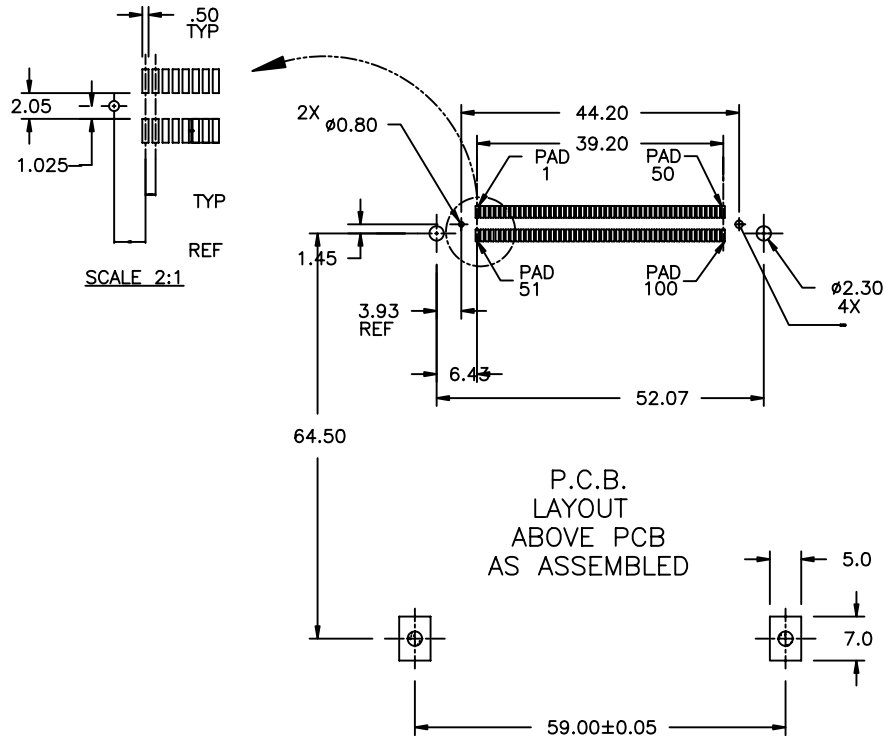

RECOMMENDED PCB LAYOUT  
53425-000, 067, 000LF, 067LF

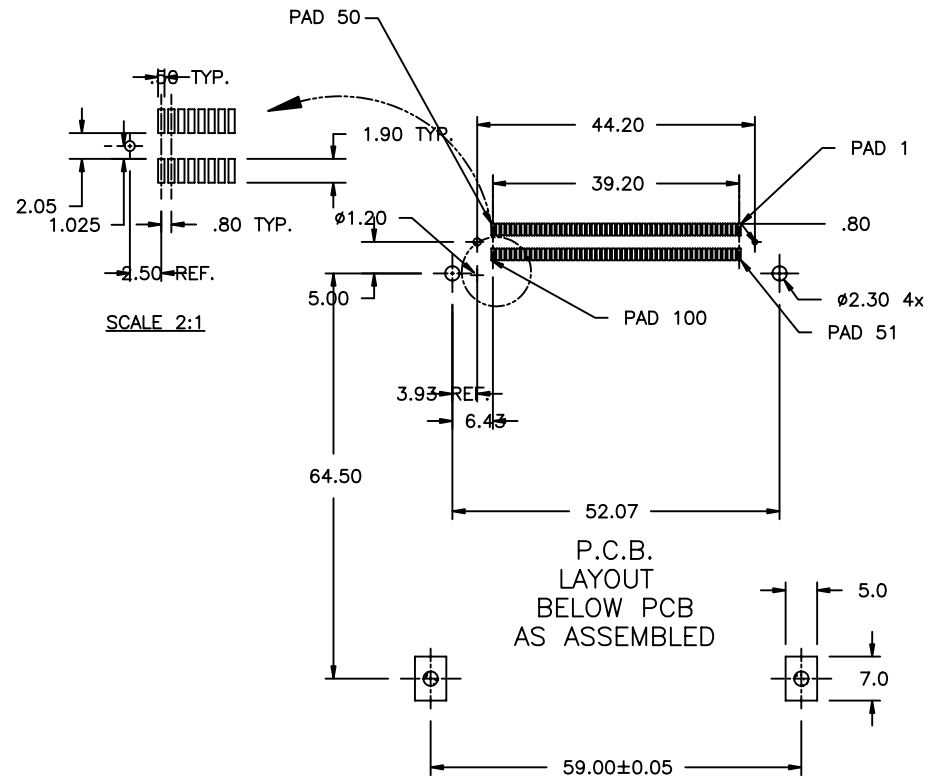

RECOMMENDED PCB LAYOUT  
53425-500 AND 500LF

mat'l. code		surface ISO 1302		tolerance ISO 406 ISO 1101		projection 1:1		product family CARDBUS	
ltr		ecn no		dr		date		title 3.3 V CARDBUS ASSEMBLY	
G								dwg no 53425	
								sheet 4 of 5 size A4	
								type CUSTOMER Drawing	
sheet index		revision sheet							

FCI CONFIDENTIAL



FCIconnect.com

This document is the property of and embodies CONFIDENTIAL and PROPRIETARY information of FCI. No part of the information shown on this document may be used in any way or disclosed to others without the written consent of FCI. Copyright FCI.

HEADER PINOUT	TYPE	BTB 100 POS RECEPTACLE	HEADER PINOUT	TYPE	BTB 100 POS RECEPTACLE
1	GND	1	35	GND	51
2	SIG	2	36	DET	52
3	SIG	3	37	SIG	53
4	SIG	5	38	SIG	55
5	SIG	6	39	SIG	56
6	SIG	8	40	SIG	58
7	SIG	9	41	SIG	59
8	SIG	11	42	SIG	61
9	SIG	12	43	SIG	62
10	SIG	14	44	SIG	64
11	SIG	15	45	SIG	65
12	SIG	17	46	SIG	67
13	SIG	18	47	SIG	68
14	SIG	20	48	SIG	70
15	SIG	21	49	SIG	71
16	SIG	23	50	SIG	73
17	PWR	24	51	PWR	74
18	SIG	27	52	SIG	77
19	SIG	28	53	SIG	78
20	SIG	30	54	SIG	80
21	SIG	31	55	SIG	81
22	SIG	33	56	SIG	83
23	SIG	34	57	SIG	84
24	SIG	36	58	SIG	86
25	SIG	37	59	SIG	87
26	SIG	39	60	SIG	89
27	SIG	40	61	SIG	90
28	SIG	42	62	SIG	92
29	SIG	43	63	SIG	93
30	SIG	45	64	SIG	95
31	SIG	46	65	SIG	96
32	SIG	48	66	SIG	98
33	SIG	49	67	DET	99
34	GND	50	68	GND	100

SHIELD PINOUT	TYPE	BTB 100 POS RECEPTACLE
1	GND	4 & 54
2	GND	7 & 57
3	GND	10 & 60
4	GND	13 & 63
5	GND	16 & 66
6	GND	19 & 69
7	GND	22 & 72
8	GND	25 & 75
9	GND	26 & 76
10	GND	29 & 79
11	GND	32 & 82
12	GND	35 & 85
13	GND	38 & 88
14	GND	41 & 91
15	GND	44 & 94
16	GND	47 & 97

NOTES:

- 1 MATERIAL:
  - 1.1 HEADER ASSY:  
PLASTIC HOUSING: LCP UL94V-0  
PIN: PHOSPHOR BRONZE
  - 1.2 NON-EJECT MECHANISM ASSY:  
PLASTIC GUIDE: POLYPHTHAMID UL94V-0 BLACK  
COVER PLATE, EJECT PLATE, LINK ARM,  
EMI CONTACT: PHOSPHOR BRONZE
- 2 FINISH (PIN)  
UNDER PLATING: 0.5um Ni  
CONTACT AREA: 0.1um GOLD OVER  
0.5um Pd-Ni  
SOLDER TAIL: 2.5um Sn-Pb FOR TIN LEAD PLATING  
2.5um PURE TIN FOR LEAD FREE PLATING
- 3 RECOMMENDED HOLD DOWN: 2mm SCREWS (95121)  
RECOMMENDED SCREW TORQUE: 1.0 TO 1.5 MAX in-lbs. (1.2-1.7 cm-kgs).
- ④ DIM "X"
 

4.25±0.1	3.5±0.1	5.0±0.1
OTHERS	36,67	1,17,34,35,51,68
- 5 MATING RECEPTACLE PART NUMBER-73277-101000 FOR TIN LEAD OPTION  
73277-101000LF FOR TIN LEAD OPTION
- 6 IF LEAD FREE P/N.THE HOUSING WILL WITHSTAND EXPOSURE TO 260°C PEAK TEMPERATURE FOR 10 SECONDS IN A WAVE SOLDER APPLICATION WITH A 1.00MM MINIMUM THICK CIRCUIT BOARD.
- 7 IF LEAD FREE P/N.THE PRODUCT MEETS EUROPEAN UNION DIRECTIVES AND OTHER COUNTRY REGULATIONS AS DISCRIBLED IN GS-22-008
8. LEAD FREE P/N PACKAGING MEETS GS-14-920 SPECIFICATION

mat'l. code		surface	tolerance	projection	product family
		ISO 1302	ISO 406 ISO 1101		CARDBUS
ltr	ecn no	dr	date	tolerances unless otherwise specified	title
G				.X±.3 linear .XX±.13 ±2' .XXX±.051	3.3 V CARDBUS ASSEMBLY
				dr R.G. Draggoo 5/15/00 enr D.BRANN 5/15/00 chr D.BRANN 5/15/00 appd D.BRANN 5/15/00	dwg no 53425 sheet 5 of 5 size A4
					type CUSTOMER Drawing
sheet index	revision sheet				